

DYE PUMP TANK & CONTROL MODULE PACKAGE

The Diamond Key International Dye Pump Tank and Control Module is designed for safe and efficient petrochemical fuel dye product supply to multiple dye injectors for loading terminals and pipelines.

MODULE PACKAGE FEATURES

The package houses the following equipment fully integrated and factory tested.

- Steel galvanized frame
- Stainless steel tanks, 250Lt
- Positive displacement pump/pumps
- Exd/Exe electric motor
- Sight level glass
- Stainless steel suction piping
- Stainless steel discharge piping
- Pump discharge check valve
- Discharge pressure gauge
- Pump by-pass valve (returned to tank)
- Suction inlet strainer
- Pump isolation valves
- Exd junction box containing manual and auto select, pump start contactors and controls (mounted in the Exd)

Options

- Low level alarm for pump protection
- High level alarm

Dimensions

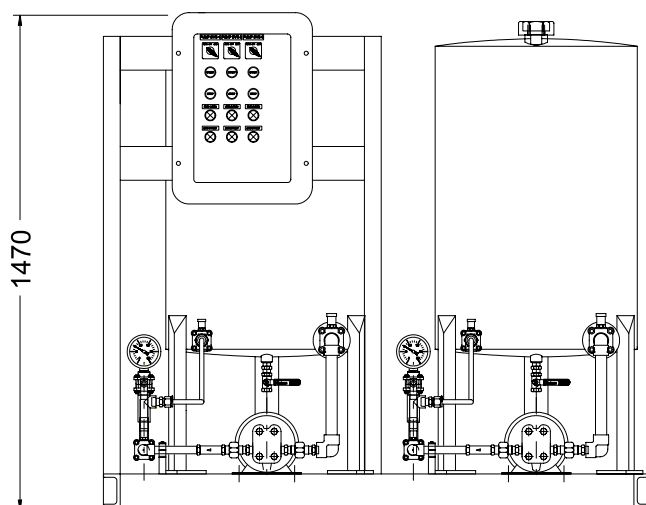

Maximum Operating Pressure

1400Kpa

Flow Rates

From 0.5 L/min to 3 L/min per pump

Power Consumption

Depending on pump selection (Contact your supplier)

Supply Power

3 Phase 380v to 415v

