

## ADDITIVE PUMP TANK & CONTROL MODULE PACKAGE

The Diamond Key International Additive Pump Tank and Control Module is designed for safe and efficient petrochemical fuel additive product supply to multiple additive injectors for loading terminals and pipelines.

### MODULE PACKAGE FEATURES

The package houses the following equipment fully integrated and factory tested.

- Steel galvanized frame
- Stainless steel tank, from 1200Lt to 5000Lt
- Positive displacement pump/pumps
- Exd/Exe electric motor
- Sight level glass
- Stainless steel suction piping
- Stainless steel discharge piping
- Pump discharge check valve
- Discharge pressure gauge
- Pump by-pass valve (returned to tank)
- Suction inlet strainer
- Pump isolation valves
- Exd junction box containing manual and auto select, pump start contactors and controls (mounted in the Exd)

### Options

- Air operated drum decanting pump and drum spear
- Electric decanting pump and drum spear (in place of the air operated above)
- Low level alarm for pump protection
- High level alarm
- Electronic level gauge

### Dimensions

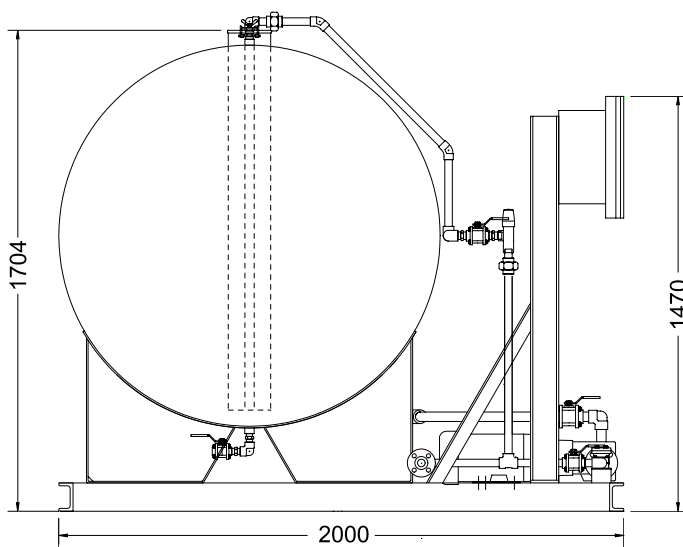

### Maximum Operating Pressure

1400Kpa

### Flow Rates

From 7 L/min to 38 L/min per pump

### Power Consumption

Depending on pump selection (Contact your supplier)

### Supply Power

3 Phase 380v to 415v

